



FIXTURE PROTECTION

HEAVY DUTY FLOOR RAIL

Your Assets First Line of Defense



SMART PROTECTION

SMART RETAIL

Heavy Duty Retail Fixture Protection

Engineered to protect high value retail fixtures from everyday impacts, our Heavy Duty Fixture Protection is specifically designed for high traffic, high impact retail environments. It extends the life of your investment while preserving a safe, clean, and professional in-store experience.

Heavy Duty Performance

Impact tested to withstand up to 5,087 joules – the equivalent of 7,000 lbs at 4 mph – delivering reliable protection in the most demanding, heavy traffic retail settings.

Twist-Lock Connection

An innovative twist lock system allows legs to be easily removed and reinstalled, simplifying maintenance, cleaning, and equipment access without disrupting store operations.

Made in North America

Designed, manufactured, and quality tested to ensure consistent performance, durability, and reliable lead times.

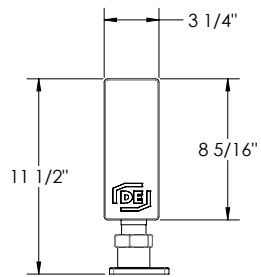
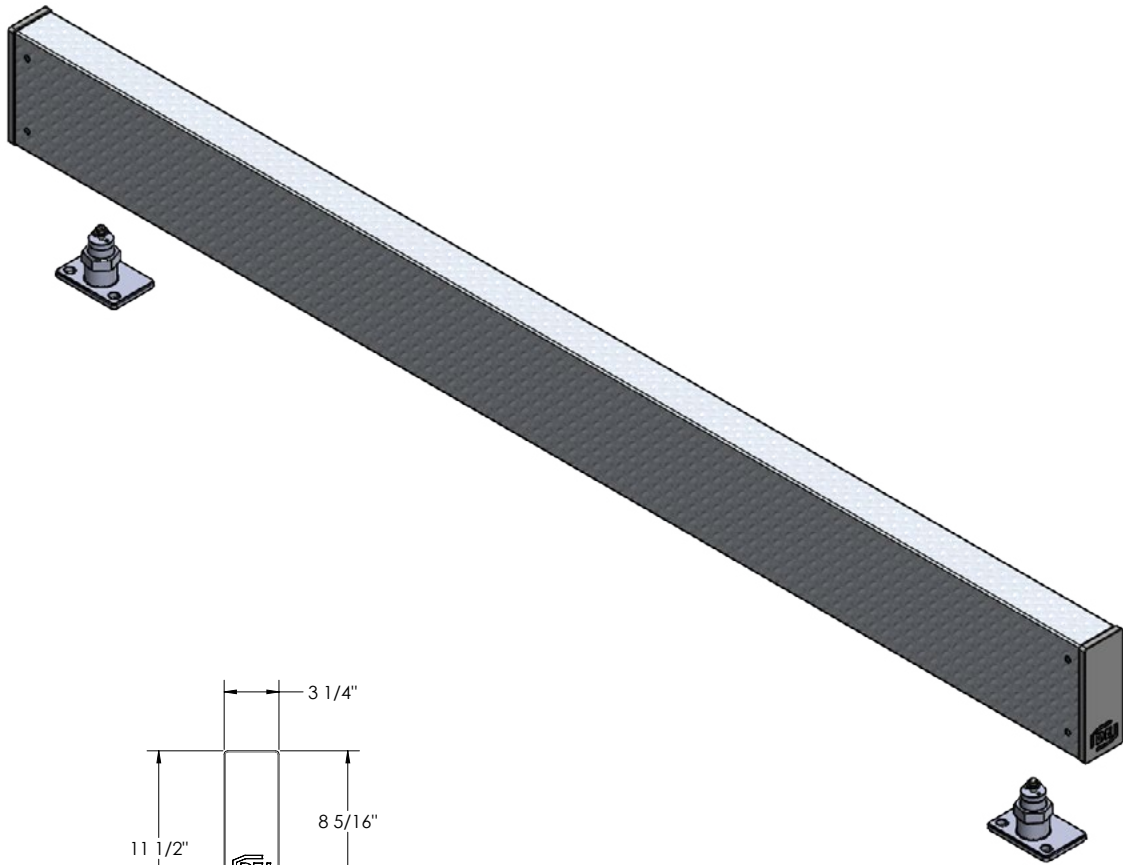

RIGHT VIEW

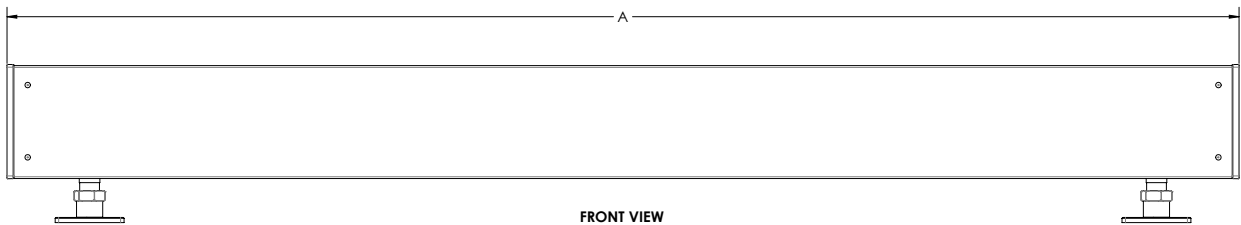



FRONT VIEW



WHY CSF DEFEND

YOUR ASSETS FIRST LINE OF DEFENSE

- 25+** Years of industry experience
- 400+** Dedicated team members
- 12** North American facilities

-  **Vertically integrated operations**
Designed, built & shipped all under one roof
-  **Customer-centric service**
Always one call away

CONTACT US

ConceptFixtures.com
 450-582-3017
info@conceptfixtures.com
[LinkedIn](#)

