



FIXTURE PROTECTION **FLOOR RAIL SYSTEM**

Your Asset's First Line of Defense

SMART PROTECTION

SMART RETAIL

Retail Fixture Protection

Engineered to protect your fixtures from everyday impacts, our Continuous Rail Design is specifically made for retail environments. It extends the life of your investment while preserving a safe, clean, and professional in-store experience.

Impact Resistant

Impact tested to withstand up to 500 joules – the equivalent of 1,800 lbs at 2.4 mph – delivering reliable protection in retail settings.

Click Connect System

Our innovative Click Connect System allows the rail to be removed and reinstalled by one person without the need for any tools, speeding up and improving routine cleaning and service.

Made in North America

Designed, manufactured, and quality tested to ensure consistent performance, durability, and reliable lead times.

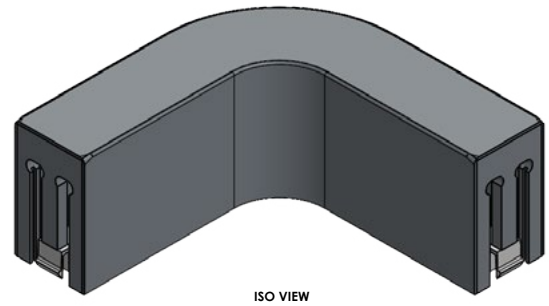
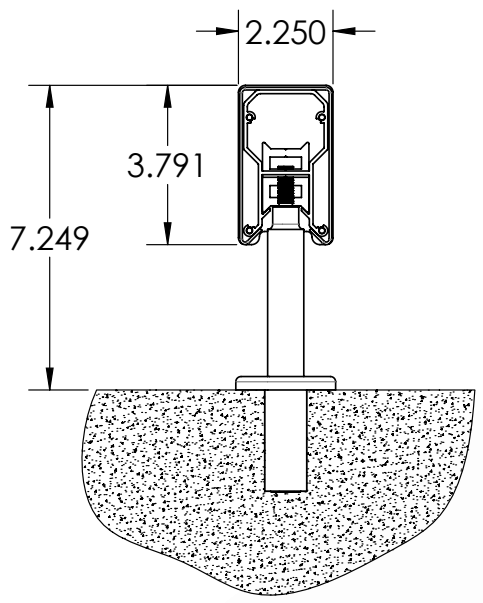
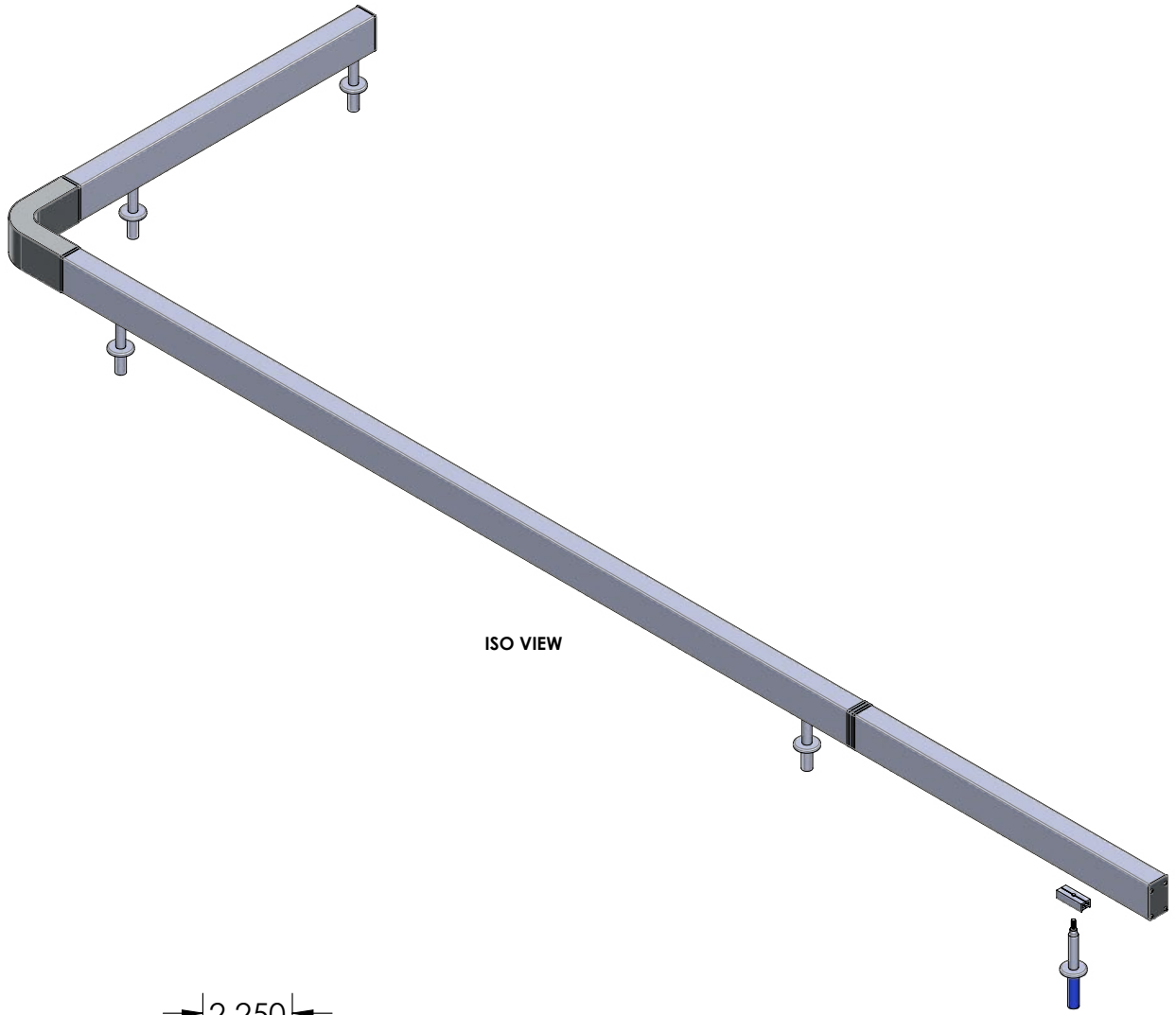





WHY CSF DEFEND

YOUR ASSET'S FIRST LINE OF DEFENSE

- 25+** Years of industry experience
- 400+** Dedicated team members
- 12** North American facilities

-  **Vertically integrated operations**
Designed, built & shipped all under one roof
-  **Customer-centric service**
Always one call away

CONTACT US

ConceptFixtures.com
 450-582-3017
info@conceptfixtures.com
[LinkedIn](#)

